

Week 2

1st
grade

Independent Study Packet

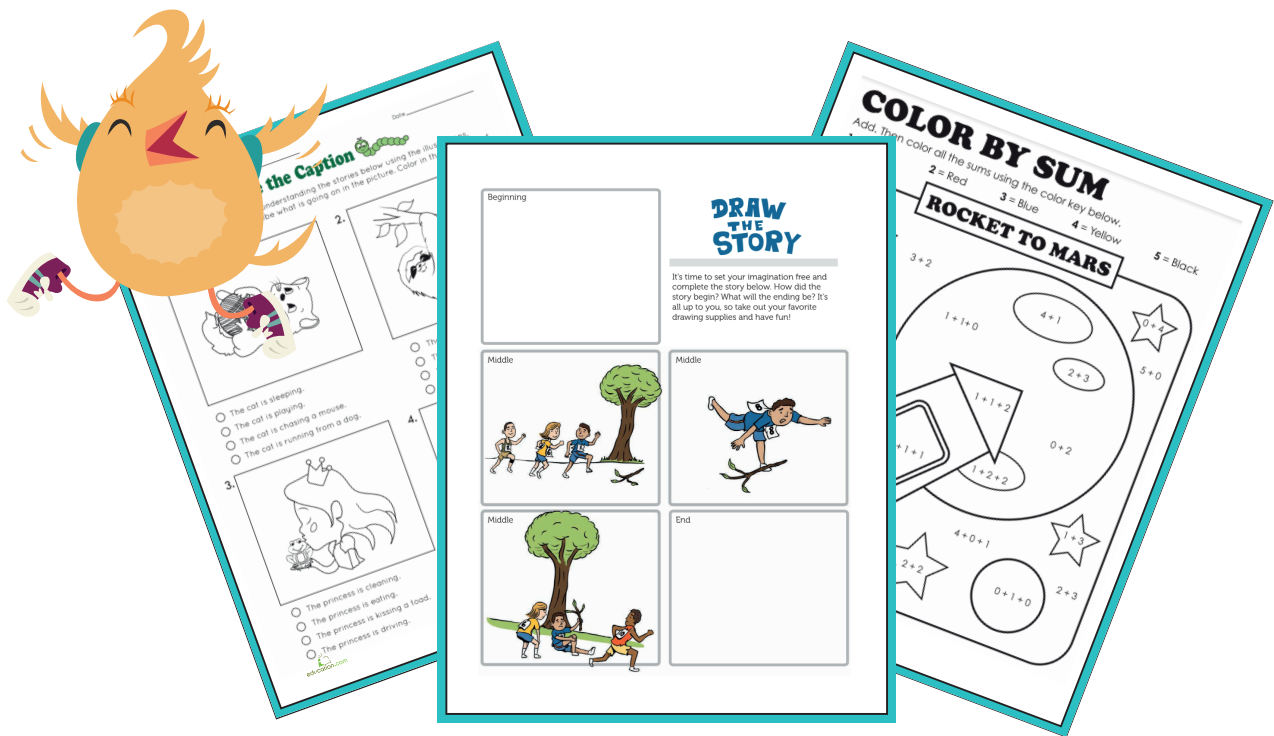

**5 MORE Days of
Independent Activities in
Reading, Writing, and Math**

**ANSWER KEYS
INCLUDED**

Helpful Hints for Students and Families

Materials You Will Need:

- Pencils
- Extra paper or a notebook/journal (everything can go in one place)
- You will need colored pencils, markers, or crayons for some of the activities.
- You will also need scissors and tape or a glue stick.
- You will also need some books to read!

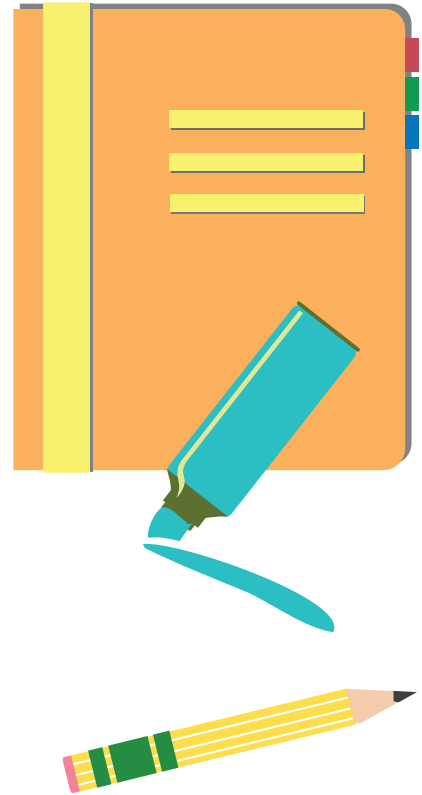





Directions & Tips

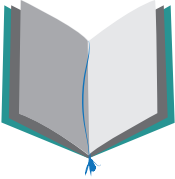

- You may complete the activities in any order.
- Check off each of the activities when you finish them on the menu.
- Make sure an adult signs the activity menu before you bring it back to school.

Activity Menu

	Day 1	Day 2	Day 3	Day 4	Day 5
Reading 	Read for 15 minutes each day and choose one activity from your reading log to complete.				
Writing	Each day, write some news about what you did in the Daily News worksheet.				
Literacy 	Goldilocks and the Three Bears Storyboard	Choose the Caption	Story Sequencing	Identifying Opposites	Draw the Story
Math 	The Number 100 Learning about 100	Position and Direction	Color by Number Sand Castle Color by Sum: Rocket to Mars	Doing Data: The Pet Store Tally	Money Practice
Other Fun Stuff 	Design Challenge: Creating a Cup Tower Pop Art Collage Make a Paper Bag Costume Chinese Writing: Numbers 1-20 Will it Fit?				



Parent/Guardian Signature: _____



Reading Log

1. Read a book by yourself or with a grown-up.
2. Put your name and the title of the book at the top of a new page.
3. Choose one of the ideas and write one or two sentences about your book. Remember, not all of the questions make sense for every book.
4. Don't forget to tell why or how you know, or both if you can!



How did the story end?	Who is your favorite character? 	Is this book like any other book you have read? Which one?
How does the main character feel in this book?	Which words in the book were tricky?	Where does the story take place (the setting)?
What is your favorite part of the story? 	What is the big problem in the story? How is it solved?	What did you learn from reading this book?
What friend or family member might like this book?	When does the story take place (the setting)?	At the end, did any characters change from how they felt at the beginning?
What is your favorite picture in the book?	What did the author want you to learn?	What surprised you in the book?

Day 1

Reading	Read for 15 minutes and complete your reading log.
Writing	Write your Daily News.
Literacy	Put this story in order.
Math	Play a 100s game!
Fun Stuff	Can you stack the cups to meet the challenge?



Goldilocks and the Three Bears Storyboard

Name: _____

Date: _____

The story is mixed up! Look at the pictures and read the words to put the story back in order again.

Bonus Activity: Color in Goldilocks and the Three Bears.



The three bears came home and saw their house was a mess!

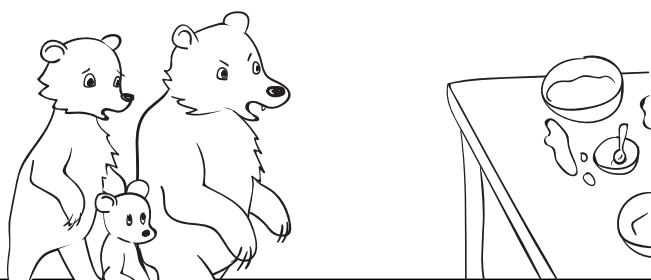

Goldilocks woke up and saw the three bears looking at her. She ran away and won't bother them again!

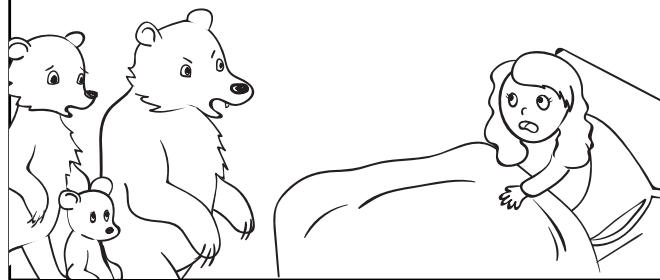

The three bears found Goldilocks in Baby bear's bed. They were upset.

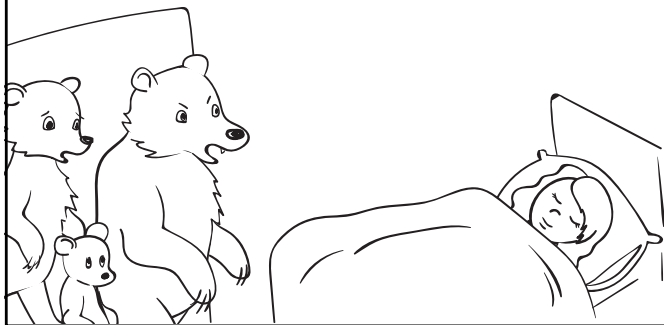

Goldilocks explored the three bears house and tried some porridge. Baby bear's porridge was just right.



The three bears left their house and went for a walk.

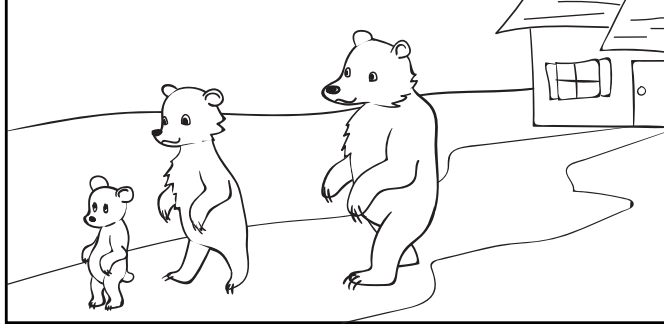

Goldilocks was tired and wanted to take a rest. Baby bear's bed was perfect.



Learning About

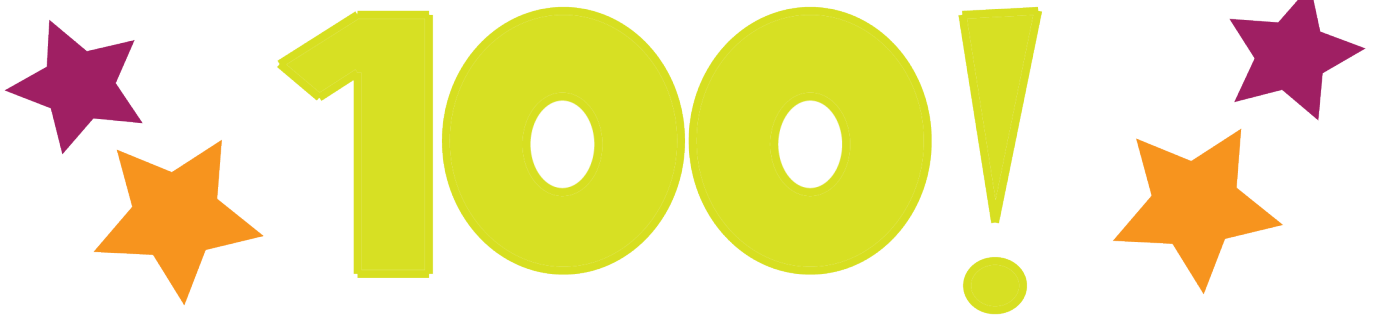

Fill in the blanks with the appropriate groups of words from below.

pencils, books

feet, miles

chips, potatoes

toothpicks, plates

toys, chores

I could carry 100 _____, but I couldn't carry
100 _____!

I could eat 100 _____,
but I couldn't eat 100 _____!

I could put 100 _____ in my backpack,
but I couldn't put 100 _____ in my backpack!

I could walk 100 _____, but I couldn't walk
100 _____!

I wish I had 100 _____, but I am glad
that I do not have 100 _____!

Design Challenge: Creating a Cup Tower

In this activity, your child will be challenged to make a tower using only one material: paper cups! The purpose of this challenge is to teach your child design thinking strategies so that they can maximize their tower's height.

What You Need:

- Paper cups
- Ruler, tape measure, or yardstick
- Pen and paper for taking notes

What You Do:

1. First, fully explain the prompt of this challenge to your child. Explain that their task is to create a cup tower and emphasize the purpose of the tower: to be as tall as possible. Tell your child that in order to achieve this, they will need to make at least a couple designs and compare their heights.
2. After your child understands the prompt, ask them to begin **brainstorming** different ways they can create their tower. Have them write or draw their ideas on a piece of paper (or you can draw their ideas while they explain them to you).
3. After your child has come up with a few design ideas, ask them to pick one that will work best. Be sure to ask them why they think this design is best and reiterate the purpose of the tower (height).
 - This is an important step of the design thinking process because it teaches your child to prioritize the purpose of their prototype (design) over their personal preferences. This will also prevent your child from getting too emotionally invested in one design.
4. Once your child has identified the prototype they think will be the tallest, give them the paper cups and allow them to **build**. We suggest allowing your child to work independently through any challenges, but be sure to supervise and help out wherever you see fit.
5. After your child has finished building, it's time to **test** their prototype. Measure the tower's height and have your child record the height on a piece of paper.
6. Since the purpose of this challenge is to build the tallest tower possible, your child will need to create at least one more prototype and compare its height with the first tower. Ask your child some of the following questions so that they can reflect on their first design:
 - a. What worked well in building this tower?
 - b. What didn't work well?
 - c. What could you change about this tower to make it taller?
7. After you and your child have come up with some modifications, explain to your child that they can now use their ideas to make a new, taller tower.
8. Once again, ask your child to **brainstorm** different designs that will hopefully create a taller tower than their first one. Then, ask them to pick the one they think will be best.
9. Next, allow your child to **build** their design. Once again, allow them to work independently as much as possible.
10. After your child has finished building, it's time to **test** their new prototype. Again, measure and record the height of their tower and compare it to the first one.
 - a. If your child's second tower is taller, ask them some of the following questions: What worked well in your second design? What didn't work well? What specific adjustment to your first design made the second tower taller? What could you change about the second design to make it even taller?
 - b. If your child's second tower is shorter than their first, ask them some of the following questions: What worked well in your second design? What didn't work well? Why do you think your second tower was shorter than the first? What could you change about this design to make it taller?
11. You and your child can continue repeating this process and attempting to create a taller tower for as long as you'd like. Be sure to cover each step of the design thinking process since repetition will reinforce these core ideas!



Day 2

Reading	Read for 15 minutes and complete your reading log.
Writing	Write your Daily News.
Literacy	Which sentence describes the picture?
Math	Practice position and direction!
Fun Stuff	Turn old magazines into art!



Choose the Caption

Billy the bookworm needs help understanding the stories below using the illustrations. Look at each illustration. Describe what is going on in the picture. Color in the bubble next to the correct answer.

1.

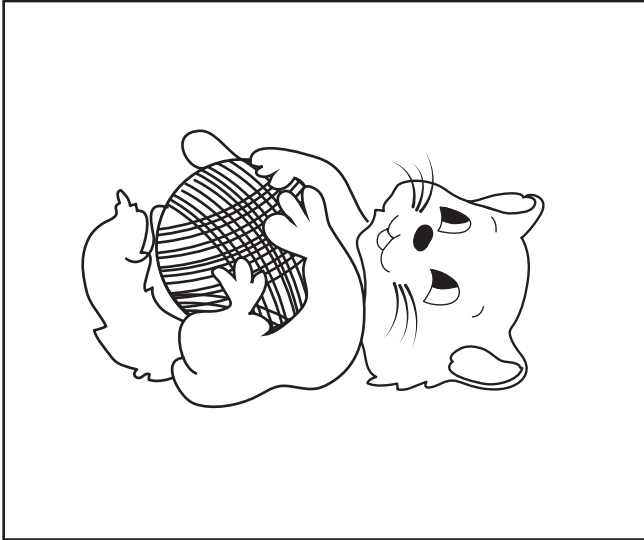

- The cat is sleeping.
- The cat is playing.
- The cat is chasing a mouse.
- The cat is running from a dog.

2.

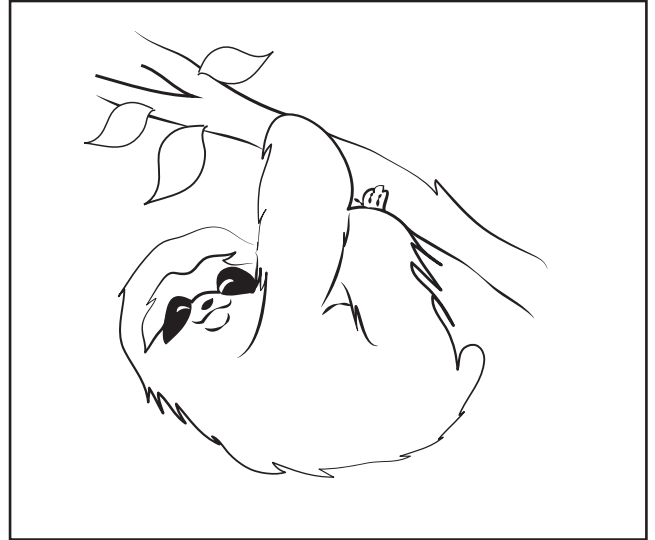

- The sloth is in a car.
- The sloth is at school.
- The sloth is at the library.
- The sloth is in a tree.

3.



- The princess is cleaning.
- The princess is eating.
- The princess is kissing a toad.
- The princess is driving.

4.



- The king is reading.
- The king is crying.
- The king is writing.
- The king is laughing.

Position and Direction

Look at the illustration on the right.
Then circle the correct answers below.

1. The stars are (**around** / **within**) the circle.
2. The X is (**outside** / **inside**) the square.
3. The arrow is on the (**left** / **right**) of the triangle.
4. The arrow is pointing (**south** / **east**).
5. The oval is (**around** / **within**) the circle.
6. The S is on the (**left** / **right**) side of the rectangle.
7. The Z is (**north** / **south**) of the rectangle.
8. The star with a black dot is (**west** / **east**) of the oval.
9. The triangle is (**below** / **above**) the rectangle.
10. The P is to the (**left** / **right**) of the arrow.

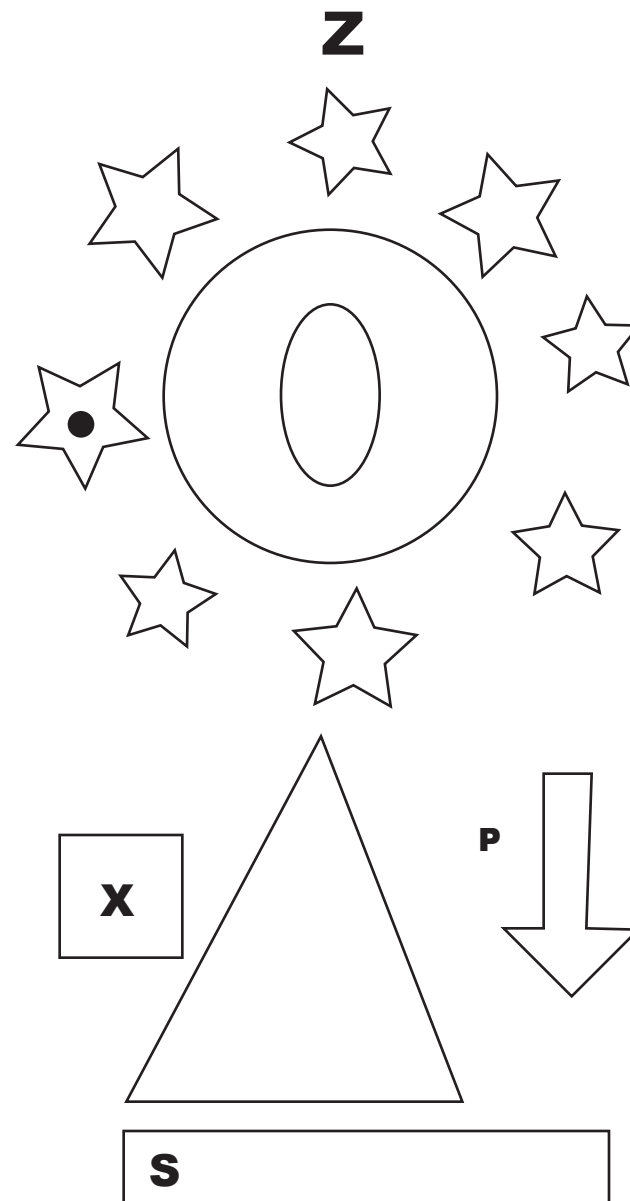

Pop Art Collage

Watch the “POP” of complementary colors while creating a fun and beautiful collage you can create from magazine clippings. Complementary colors sets are; violet/yellow, green/red and orange/ blue. Have your child choose his favorite set and then it’s time to rip, shred and tear colors out of old magazines while creating a fun gift for loved ones!

What You Need:

- Old magazines
- Glue stick
- White Construction paper 11” x 17”



What You Do:

1. Discuss complementary colors with your child. Allow them to choose his favorite complementary set that will be used for his card.
2. Have him fold his white paper in half and assign one color to each side of the paper. An example would be blue on one half of the page and orange on the other half.
3. He can tear out colors from magazines that match the color pair he’s chosen. Encourage him to tear the paper into various shapes and sizes.
4. Now, he can assemble them onto the white paper as a collage, creating one side at a time until all white areas of the paper are covered.
5. If he wants, your child can fold it in half to make a card, and write a special message to a loved one on the inside of the card!

Helpful Hint:

Artists often use complementary colors to make images “pop” because when placed next to each other, the color frequencies cause the eye to literally vibrate. This is where the term “Pop Art” comes from!

Day 3

Reading	Read for 15 minutes and complete your reading log.
Writing	Write your Daily News.
Literacy	Choose what is happening in the story.
Math	Color the castle by matching the right numbers, then color the rocket by adding.
Fun Stuff	Make a paper bag costume.



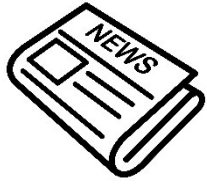

My Daily News

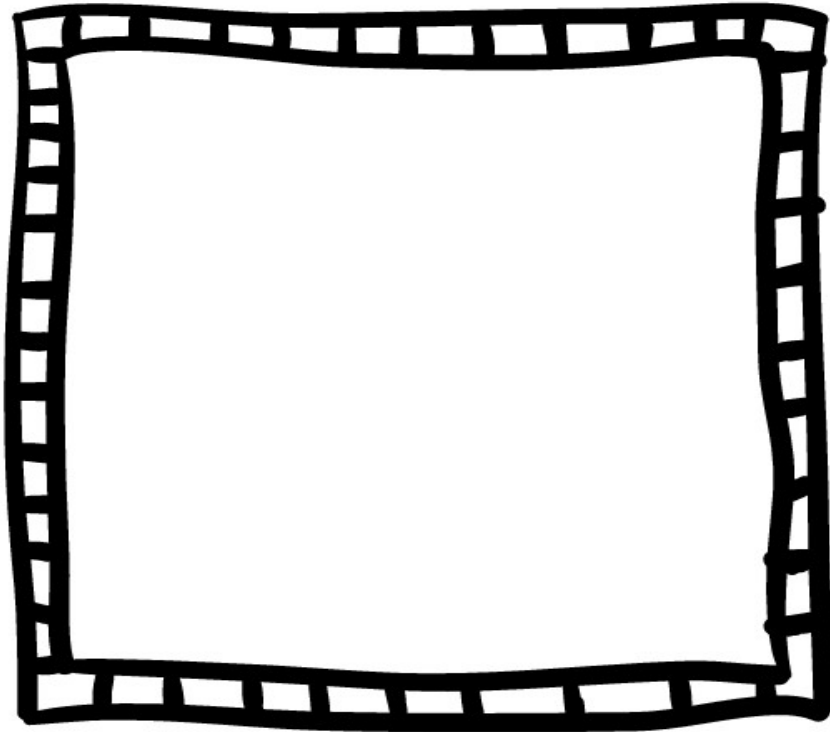

Some ways to start
your Daily News:

Today I
I went
I learned
I saw

Or, pick your own
way to start!

Story Sequencing

Name: _____

Date: _____

Look at each group of pictures and decide what happened. Fill in the bubble next to the best answer.

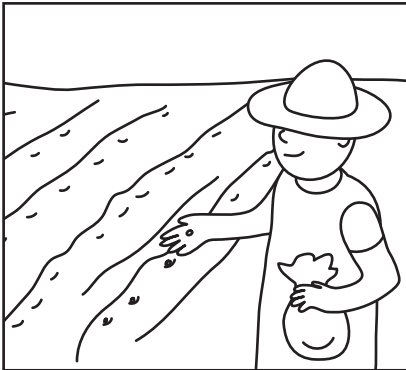

- The sun was shining on the farm.
- The farmer planted seeds and the seeds grew into plants.
- The farm is a fun place to work.

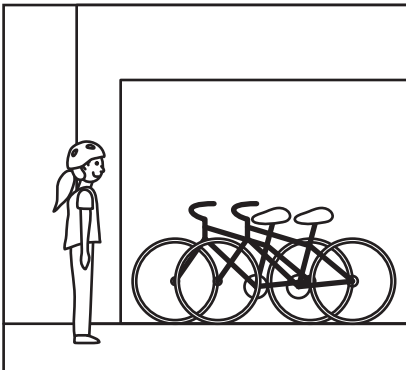
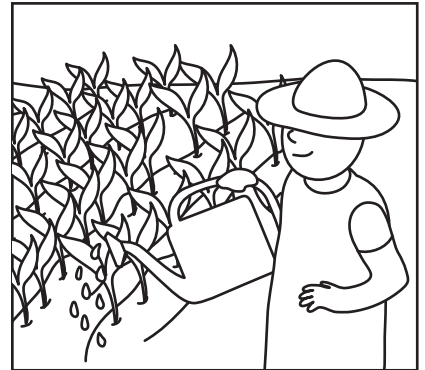

- The kids got out their bikes and went for a ride.
- The bikes were broken and the kids were sad.
- The kids were looking for their bikes.

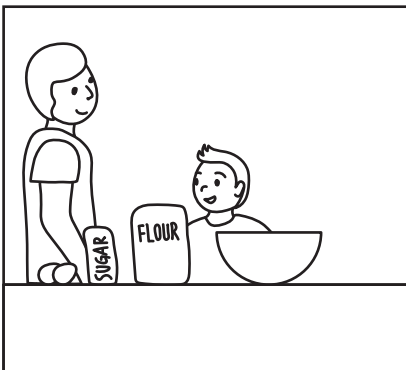
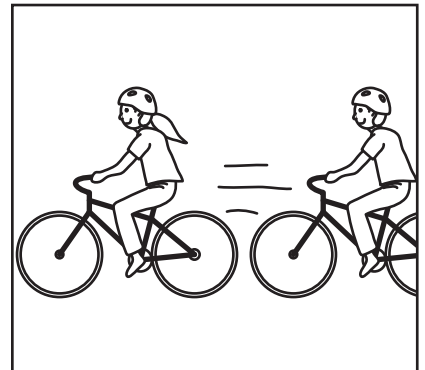

- The boy and his dad are playing a game outside.
- The boy is eating a cake.
- The boy and his dad are making a cake.



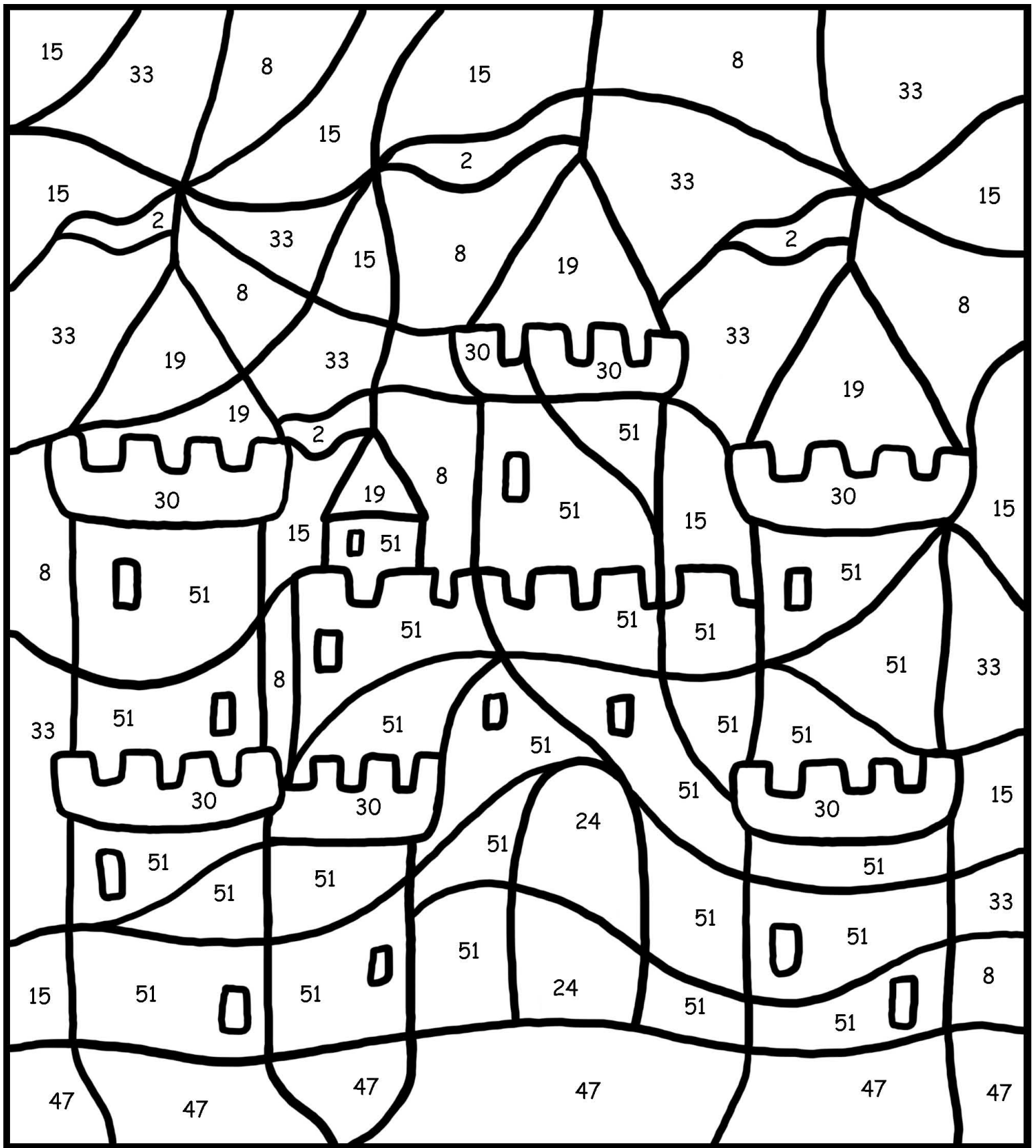

What is hiding in those numbers?

2 - red, 19 - Blue, 24 - Black, 30 - Yellow, 47 - Green, 51 - Gray

COLOR BY SUM

Add. Then color all the sums using the color key below.

1 = Green

2 = Red

3 = Blue

4 = Yellow

5 = Black

ROCKET TO MARS

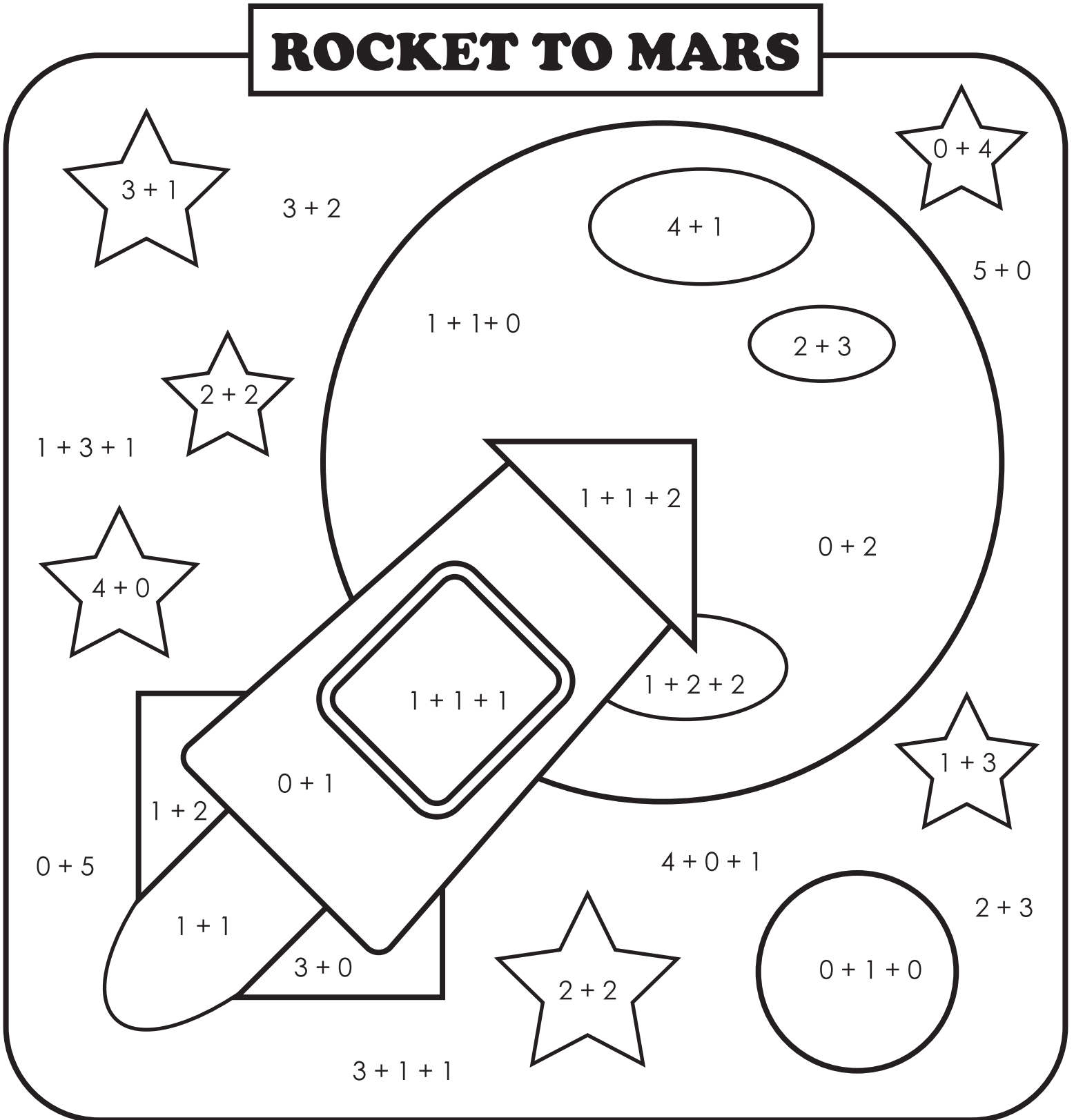

Make a Paper Bag Costume

Recycle large brown paper shopping bags by making them into dress-up costumes. Your child can decorate her costume with recycled embellishments such as buttons, cord, yarn and scraps of paper or magazines. A great activity for aspiring designers.

What You Need:

- [Paper Bag Costume Guide](#)
- Brown paper bag
- Colored construction paper
- Paints
- Collage scraps, buttons, cord, yarn, fabric scraps
- Glue



What You Do:

1. Prepare the brown paper bag by holding it upside down and cutting out a hole in the middle of the bottom gutter (approx. 6-1/2"x6-1/2") through which your child's head will go, and holes for the hands (approx. 6"x6"). Indent in a curved shape into the front of the bag (see attached diagram 1) and cut off the handle. Cut a slit in the back to make it easier for your child to get the costume over his head. See the [Paper Bag Costume Guide](#) for reference.
2. The front and back of the bag should look like diagrams 3 and 4.
3. Lay some newspaper on the floor and over the chair back to protect them from stains.
4. Slide the bag over the back of a chair on top of the newspaper and let your child decorate with the paint, scraps and embellishments.
5. Allow costume to dry completely if painted or glued.

The costume is now ready to wear! You can make the costume longer by cutting up another brown paper bag and sticking it to your basic bag. A fanned piece of construction paper stuck down at the centre makes a great bow tie!

Day 4

Reading	Read for 15 minutes and complete your reading log.
Writing	Write your Daily News.
Literacy	Find the opposites of these words.
Math	Tally things up at the pet store!
Fun Stuff	Learn to write the numbers 1-20 in Chinese.



Opposites

Draw a line connecting the pictures which are opposites.



happy



cold



quiet



day



empty



noisy



night



sad



hot

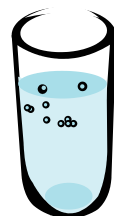

full

Data: Pet Store Tally

Where do your furry friends get their groceries? At the Pet Store! Count and record the number of each type of animal in the tally chart below. Then answer the questions on the following page!



Type of Animal	Tally	Total
Insect		4
Fish		
Bird		
Cat		
Dog		
	Grand Total	

Name _____

Date _____

Pet Store Questions

1. How many more fish are there than dogs?

2. How many more insects are there than birds?

3. Which two types of animals total the same amount?

4. Which type of animal is there the most of?

5. Which type of animal is there the fewest of?

6. How many animals are there altogether?

Name _____ Date _____

學習中文 *beginner*

LEARNING CHINESE

NUMBERS 1-10

Practice writing numbers 1 to 10 using the correct stroke order.



1

yī

2

èr

3

sān

4

sì

5

wu

6

liù

7

qī

8

bā

9

jiu

10

shí

一	二	三	四	五	六	七	八	九	十
→	→	→	↓	→	↖	↗	↘	↙	→
一	→	三	四	五	六	七	八	九	十
一	二	三	四	五	六	七	八	九	十
一	二	三	四	五	六	七	八	九	十
一	二	三	四	五	六	七	八	九	十
一	二	三	四	五	六	七	八	九	十
一	二	三	四	五	六	七	八	九	十
一	二	三	四	五	六	七	八	九	十

Use the template below to practice writing numbers 1 to 10, following the stroke order on the previous page. (**tip**: practice saying the numbers out loud as you write!)

1

yī

2

èr

3

sān

4

sì

5

wu

6

liù

7

qī

8

bā

9

jiu

10

shí

一

二

三

四

五

六

七

八

九

十

Day 5

Reading	Read for 15 minutes and complete your reading log.
Writing	Write your Daily News.
Literacy	Draw how this story starts and ends.
Math	Find the total amount of the coins.
Fun Stuff	Will everything fit in the shopping cart?



Beginning

DRAW THE STORY

It's time to set your imagination free and complete the story below. How did the story begin? What will the ending be? It's all up to you, so take out your favorite drawing supplies and have fun!

Middle



Middle



Middle

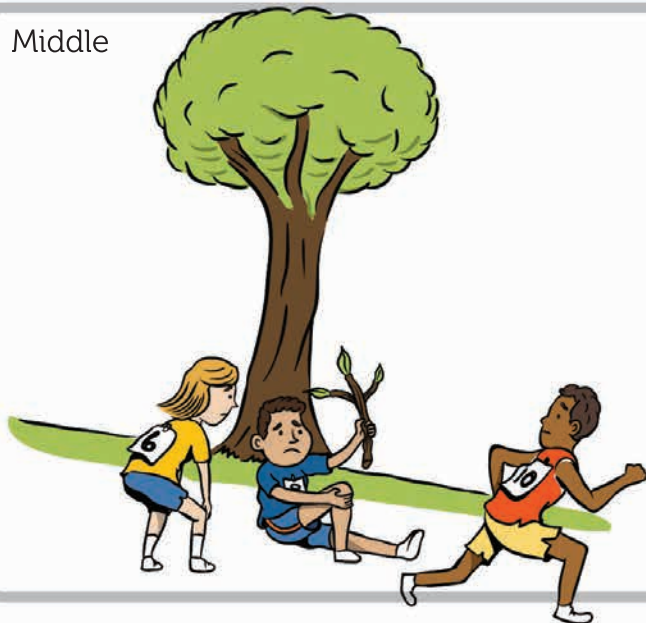

End

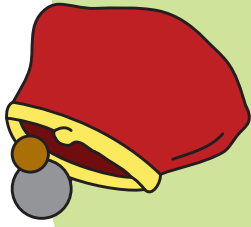

Money Practice

Count the coins. Fill in the circle next to the correct answer.



26¢



93¢



62¢



38¢



12¢



63¢



93¢



88¢



76¢



41¢



67¢



83¢



8¢



13¢

18¢



29¢



24¢



21¢



92¢



82¢



72¢



71¢



28¢



31¢

Will it fit?

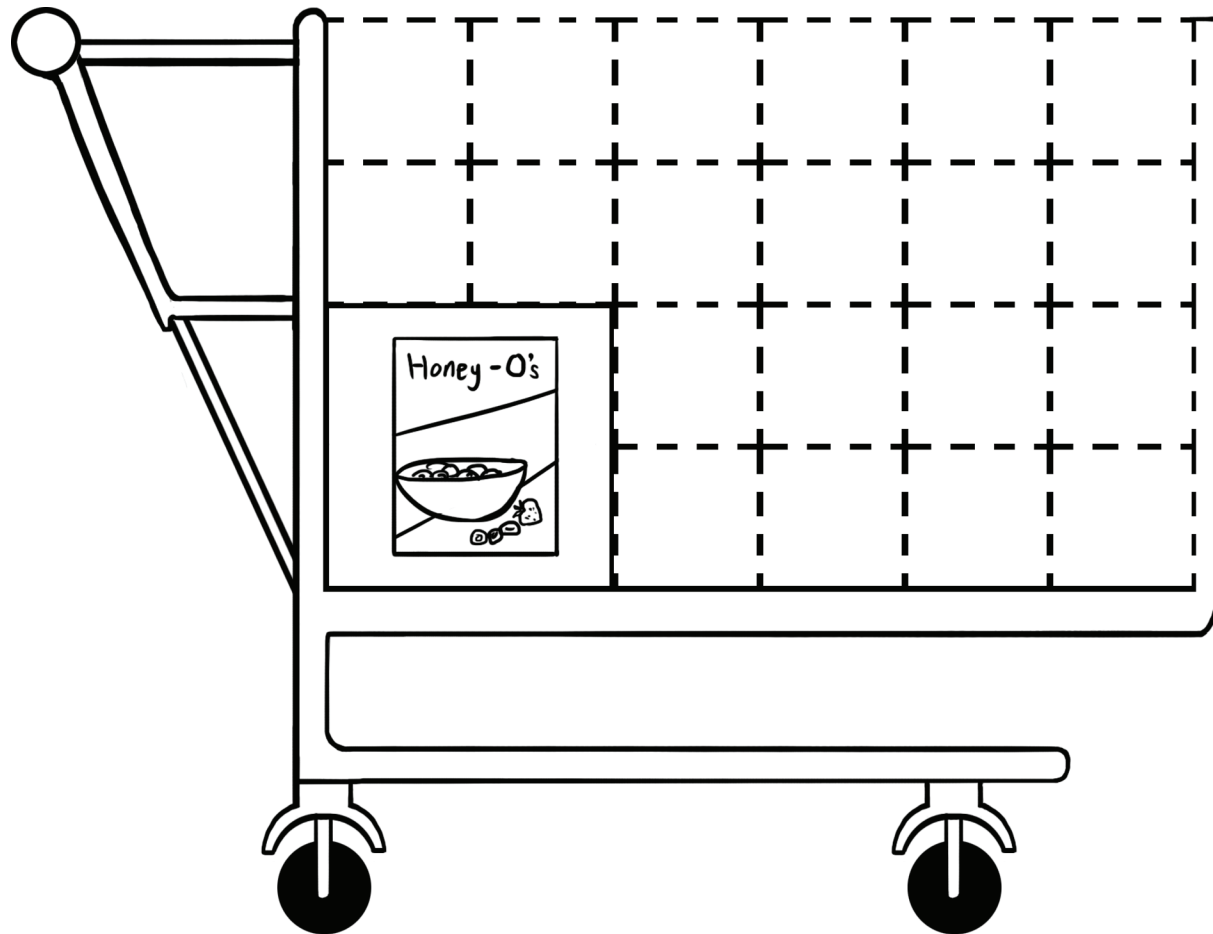

Cut out the shapes below and place them inside the dotted line area in the shopping cart above. Try turning some shapes around to see if they'll fit!

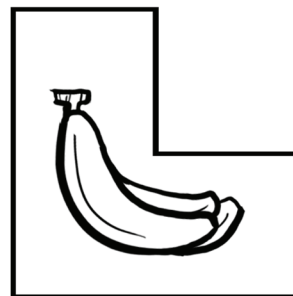
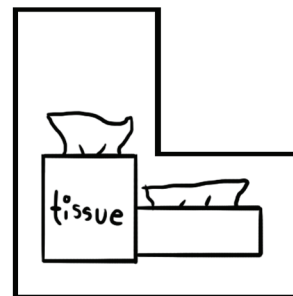
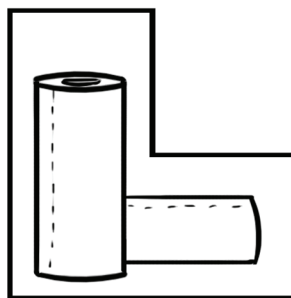

Will it fit?

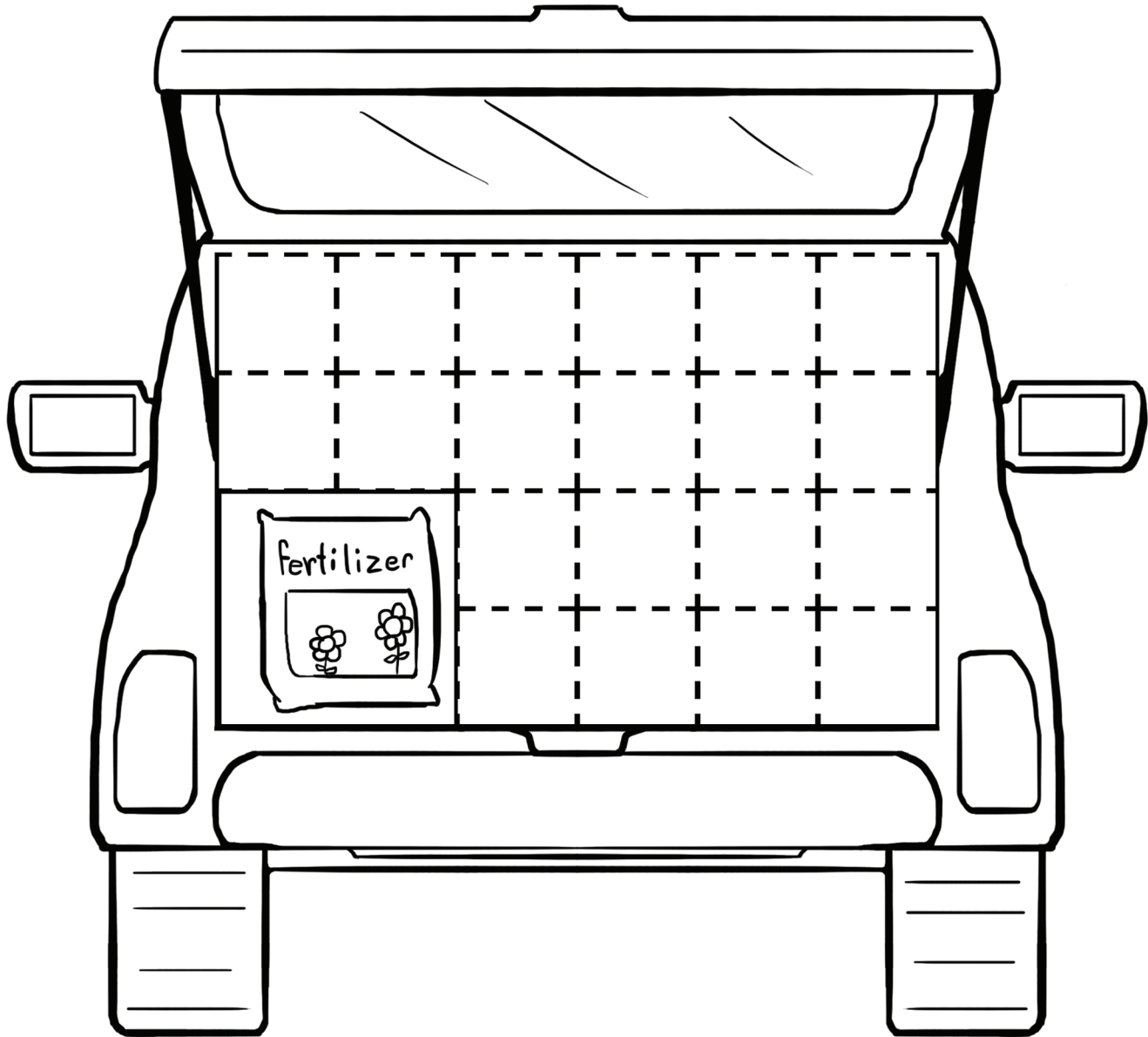

Cut out the shapes below and place them inside the dotted line area in the cart trunk above. Try turning some shapes around to see if they'll fit!

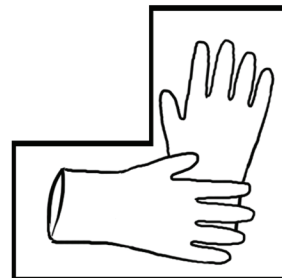
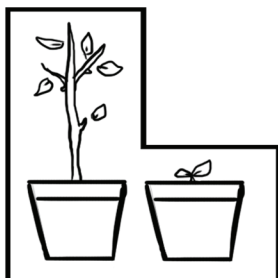
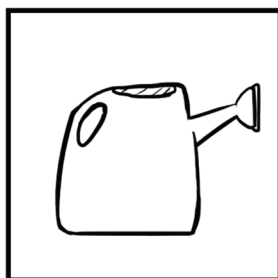
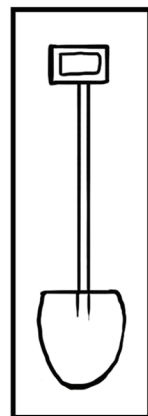
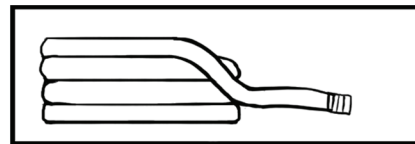
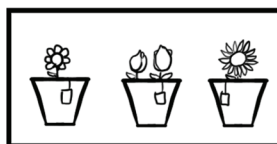
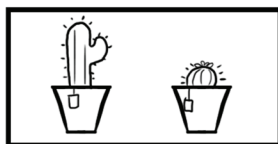

Will it fit?

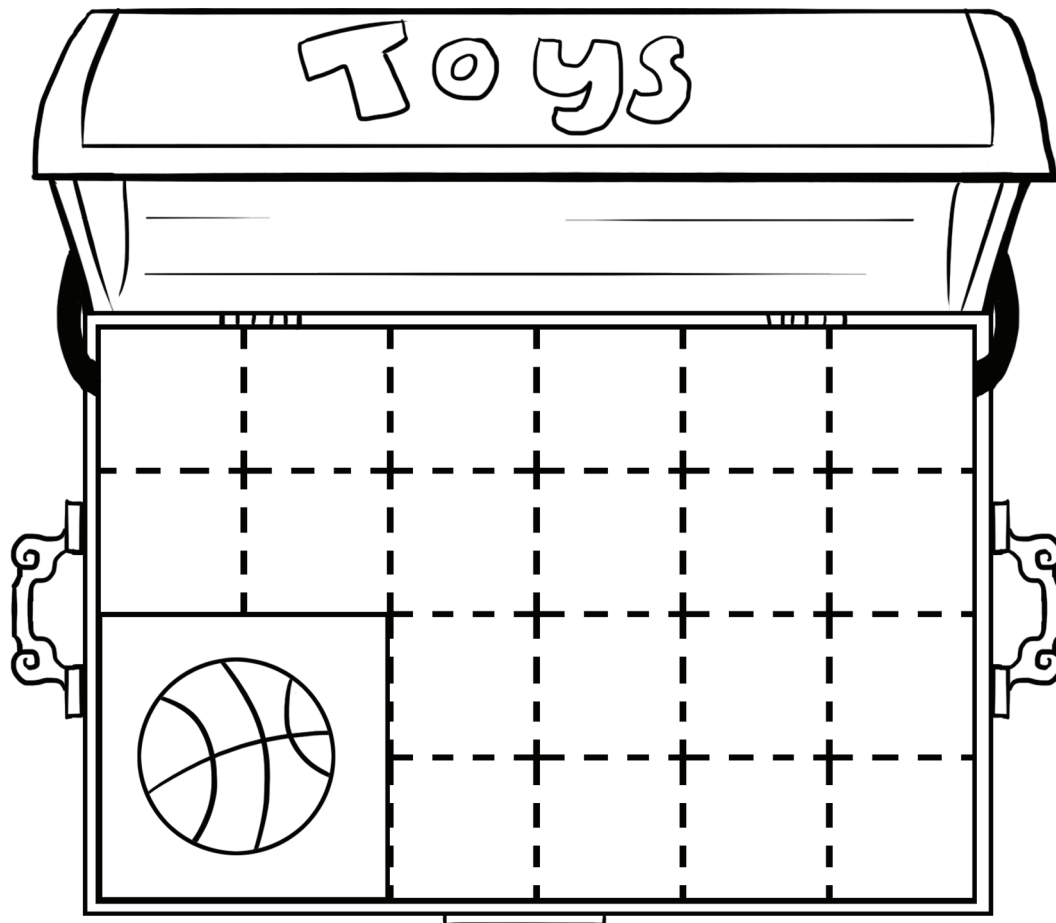

Cut out the shapes below and place them inside the dotted line area in the toy chest above. Try turning some shapes around to see if they'll fit!

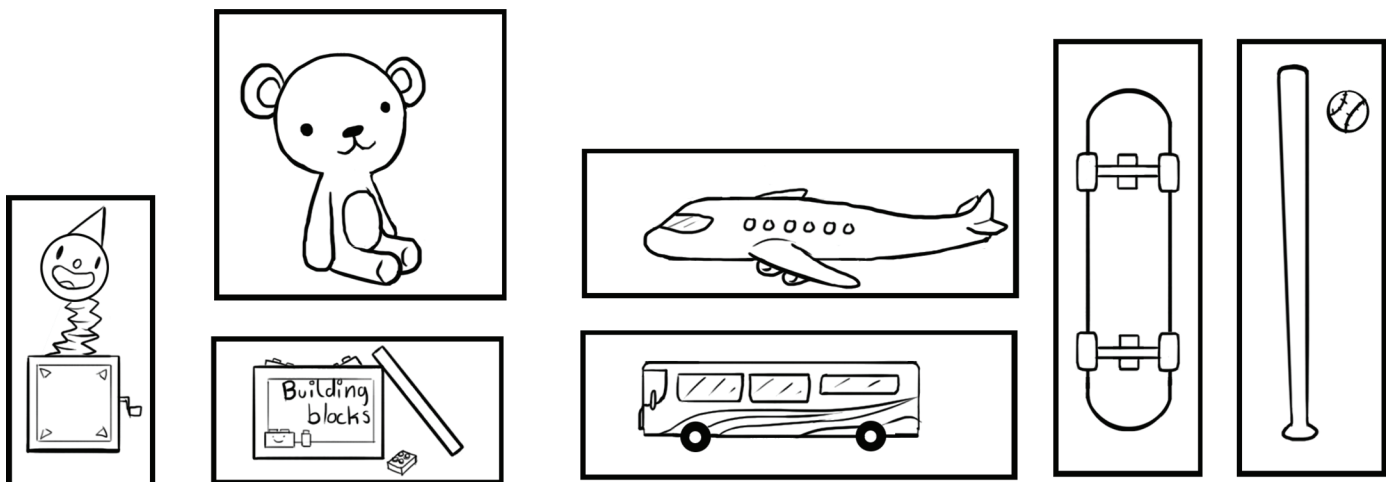

Week 2

Independent Study Packet

ANSWER KEYS

**Use these answer keys
to check your work!**



© ThuVienTiengAnh.Com

Answer Key Goldilocks and the Three Bears Storyboard

Name: _____

Date: _____

The story is mixed up! Look at the pictures and read the words to put the story back in order again.

Bonus Activity: Color in Goldilocks and the Three Bears.

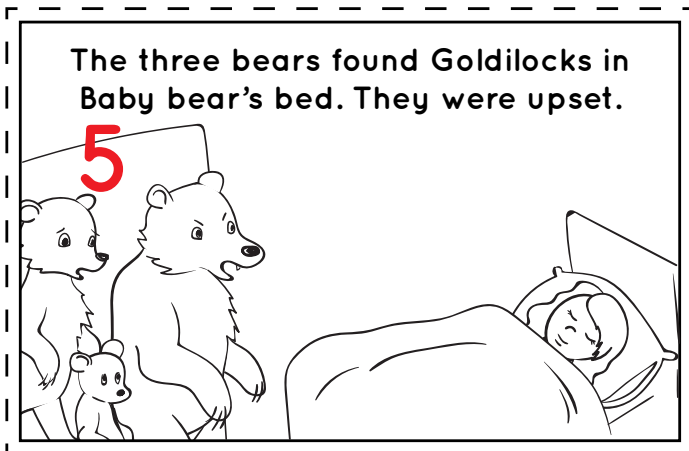
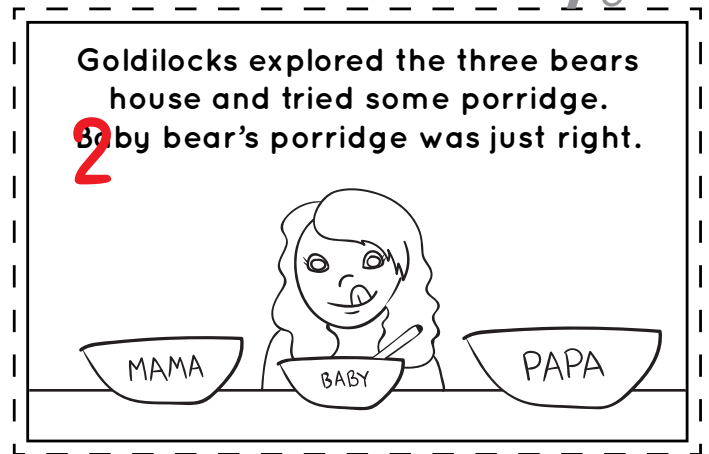
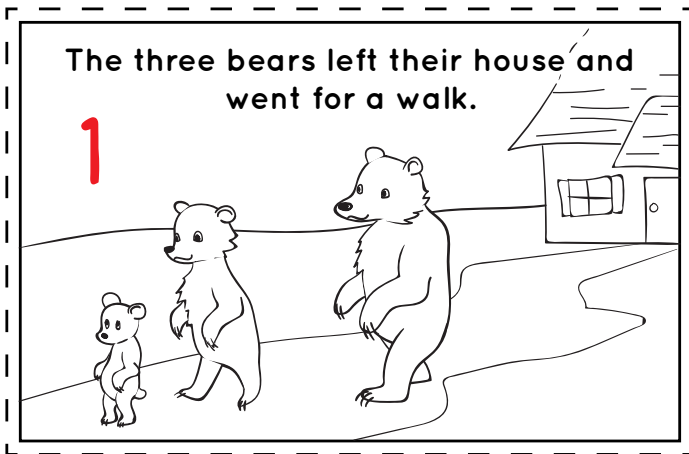

Answer Key Choose the Caption

Billy the bookworm needs help understanding the stories below using the illustrations. Look at each illustration. Describe what is going on in the picture. Color in the bubble next to the correct answer.

1.

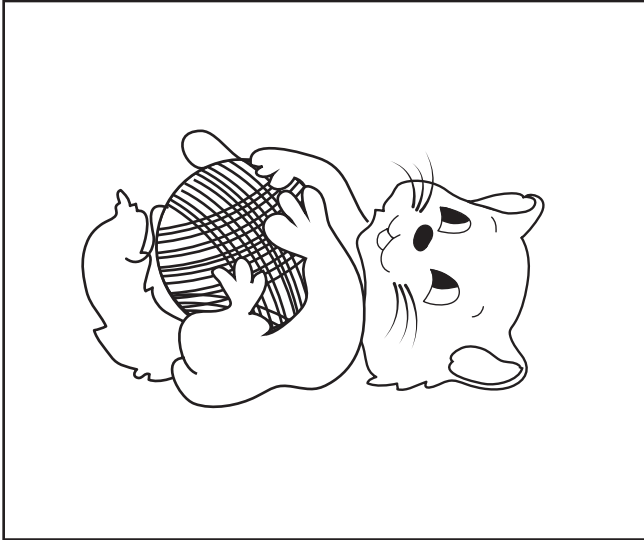

- The cat is sleeping.
- The cat is playing.
- The cat is chasing a mouse.
- The cat is running from a dog.

2.

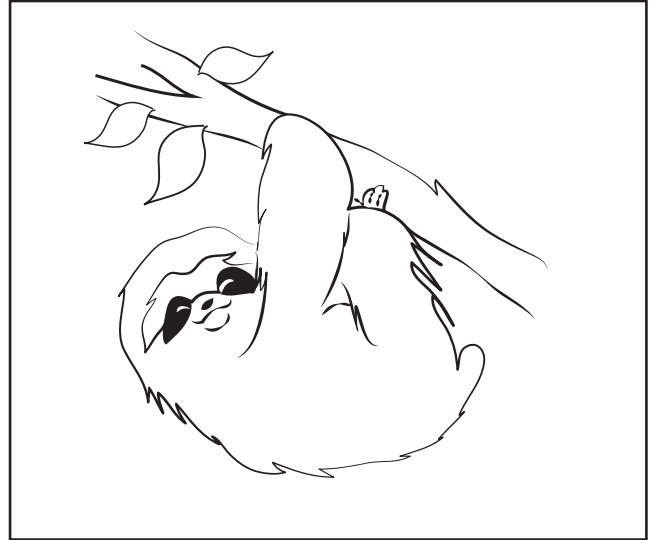

- The sloth is in a car.
- The sloth is at school.
- The sloth is at the library.
- The sloth is in a tree.

3.



- The princess is cleaning.
- The princess is eating.
- The princess is kissing a toad.
- The princess is driving.

4.



- The king is reading.
- The king is crying.
- The king is writing.
- The king is laughing.

Position and Direction Answer Key

Look at the illustration on the right.
Then circle the correct answers below.

1. The stars are (**around** / **within**) the circle.
2. The X is (**outside** / **inside**) the square.
3. The arrow is on the (**left** / **right**) of the triangle.
4. The arrow is pointing (**south** / **east**).
5. The oval is (**around** / **within**) the circle.
6. The S is on the (**left** / **right**) side of the rectangle.
7. The Z is (**north** / **south**) of the rectangle.
8. The star with a black dot is (**west** / **east**) of the oval.
9. The triangle is (**below** / **above**) the rectangle.
10. The P is to the (**left** / **right**) of the arrow.

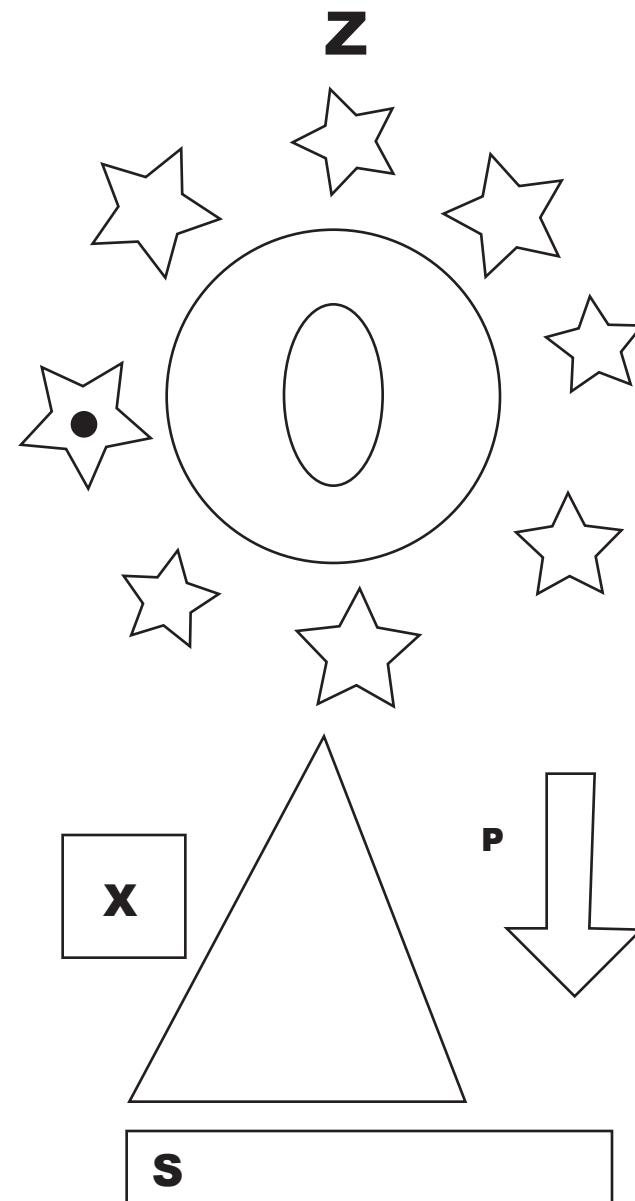

Answer Key Story Sequencing

Name: _____

Date: _____

Look at each group of pictures and decide what happened. Fill in the bubble next to the best answer.

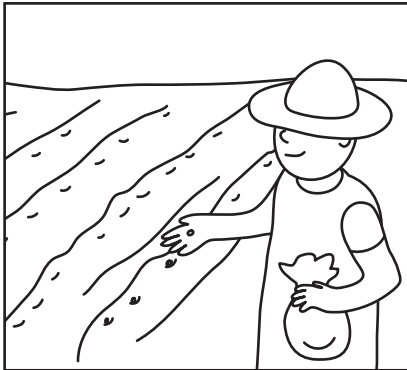

- The sun was shining on the farm.
- The farmer planted seeds and the seeds grew into plants.
- The farm is a fun place to work.

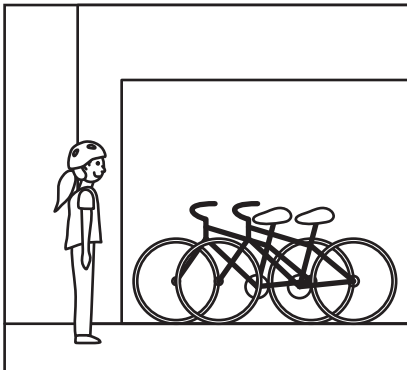
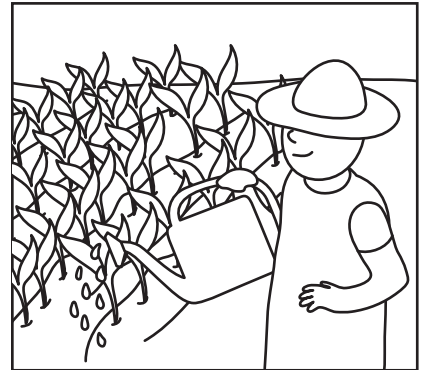

- The kids got out their bikes and went for a ride.
- The bikes were broken and the kids were sad.
- The kids were looking for their bikes.

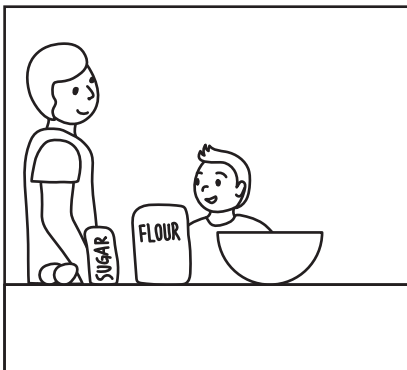
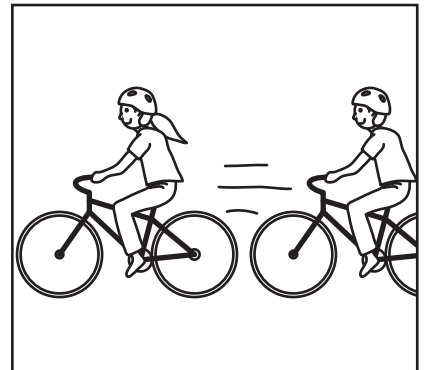

- The boy and his dad are playing a game outside.
- The boy is eating a cake.
- The boy and his dad are making a cake.





Answer Key

What is hiding in those numbers?

2 - red, 19 - Blue, 24 - Black, 30 - Yellow, 47 - Green, 51 - Gray

COLOR BY SUM Answer Key

Add. Then color all the sums using the color key below.

1 = Green

2 = Red

3 = Blue

4 = Yellow

5 = Black

ROCKET TO MARS

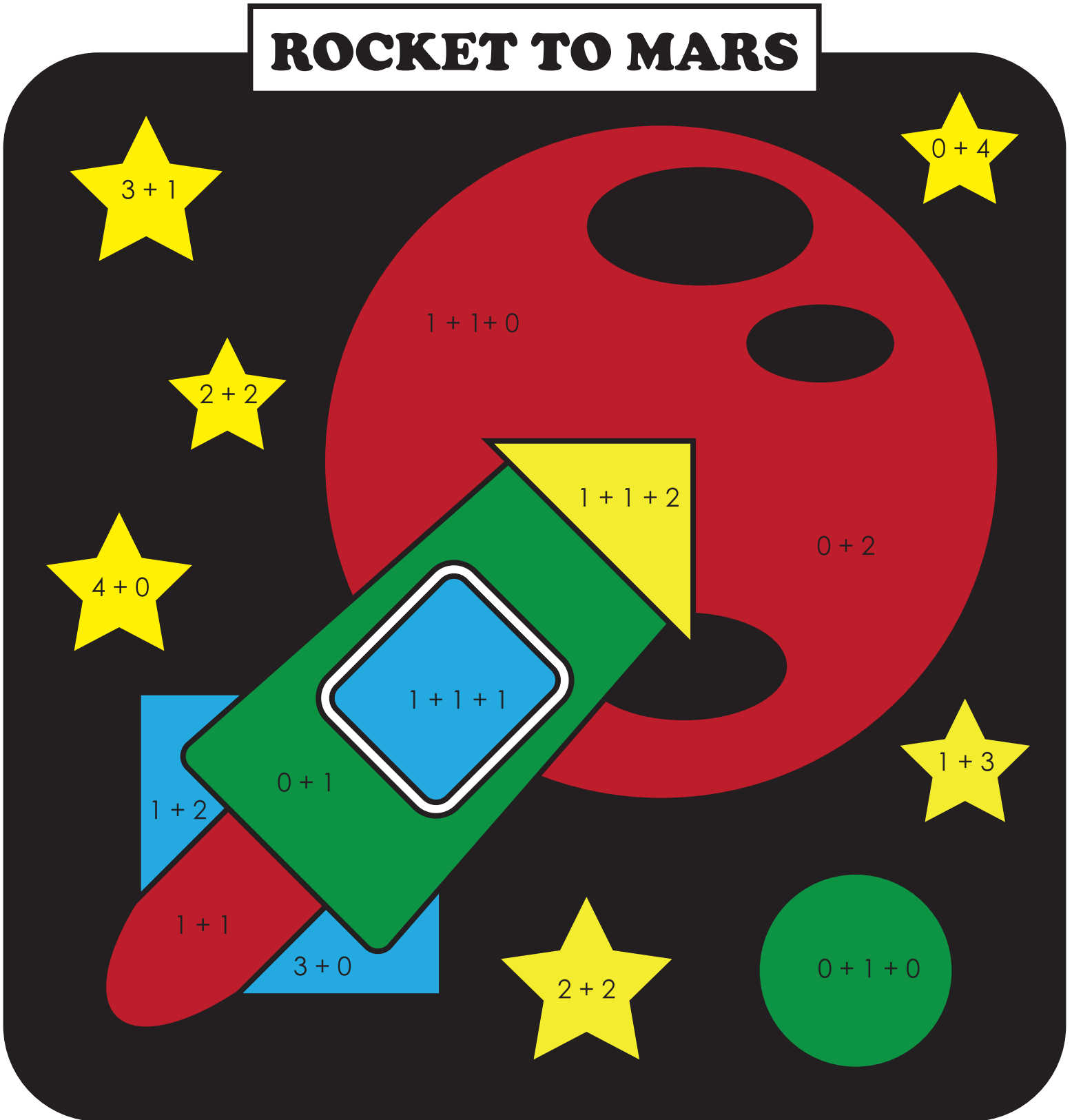

Opposites

Draw a line connecting the pictures which are opposites.



happy



cold



quiet



day



empty



noisy



night



sad



hot

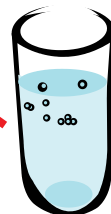

full

Answer Key

Data: Pet Store Tally

Where do your furry friends get their groceries? At the Pet Store! Count and record the number of each type of animal in the tally chart below. Then answer the questions on the following page!



Type of Animal	Tally	Total
Insect		4
Fish		4
Bird		3
Cat		5
Dog		2
	Grand Total	18

Name _____

Date _____

Answer Key

Pet Store Questions

1. How many more fish are there than dogs?

There are two more fish than dogs.

2. How many more insects are there than birds?

There is one more insect than birds.

3. Which two types of animals total the same amount?

Insects and fish.

4. Which type of animal is there the most of?

There are the most cats.

5. Which type of animal is there the fewest of?

There are the fewest dogs.

6. How many animals are there altogether?

There are 18 animals in total.

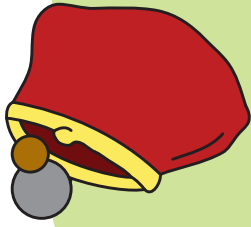

Money Practice

Count the coins. Fill in the circle next to the correct answer.

Answer Key



26¢



93¢



62¢



38¢



12¢



63¢



93¢



88¢



76¢



41¢



67¢



83¢



8¢



13¢

18¢



29¢



24¢



21¢



92¢



82¢



72¢



71¢



28¢



31¢

Answer Key

Will it fit?

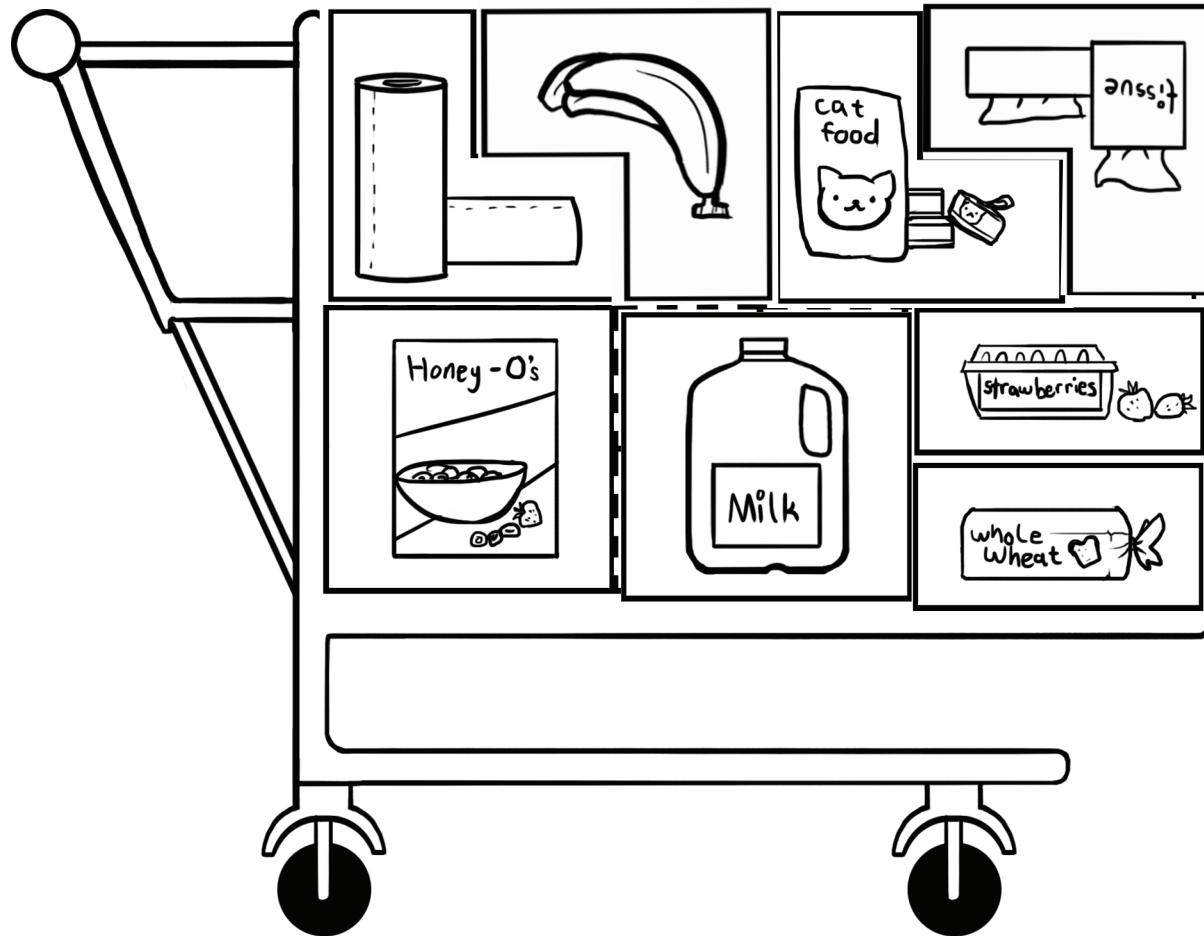

Cut out the shapes below and place them inside the dotted line area in the shopping cart above. Try turning some shapes around to see if they'll fit!

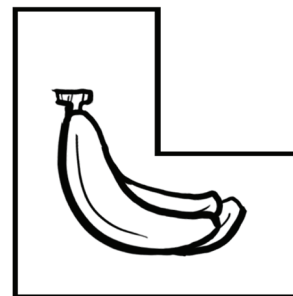
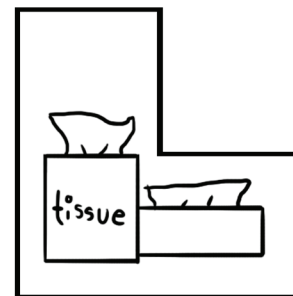
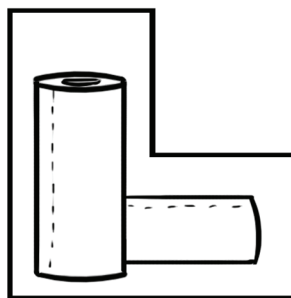

Answer Key

Will it fit?

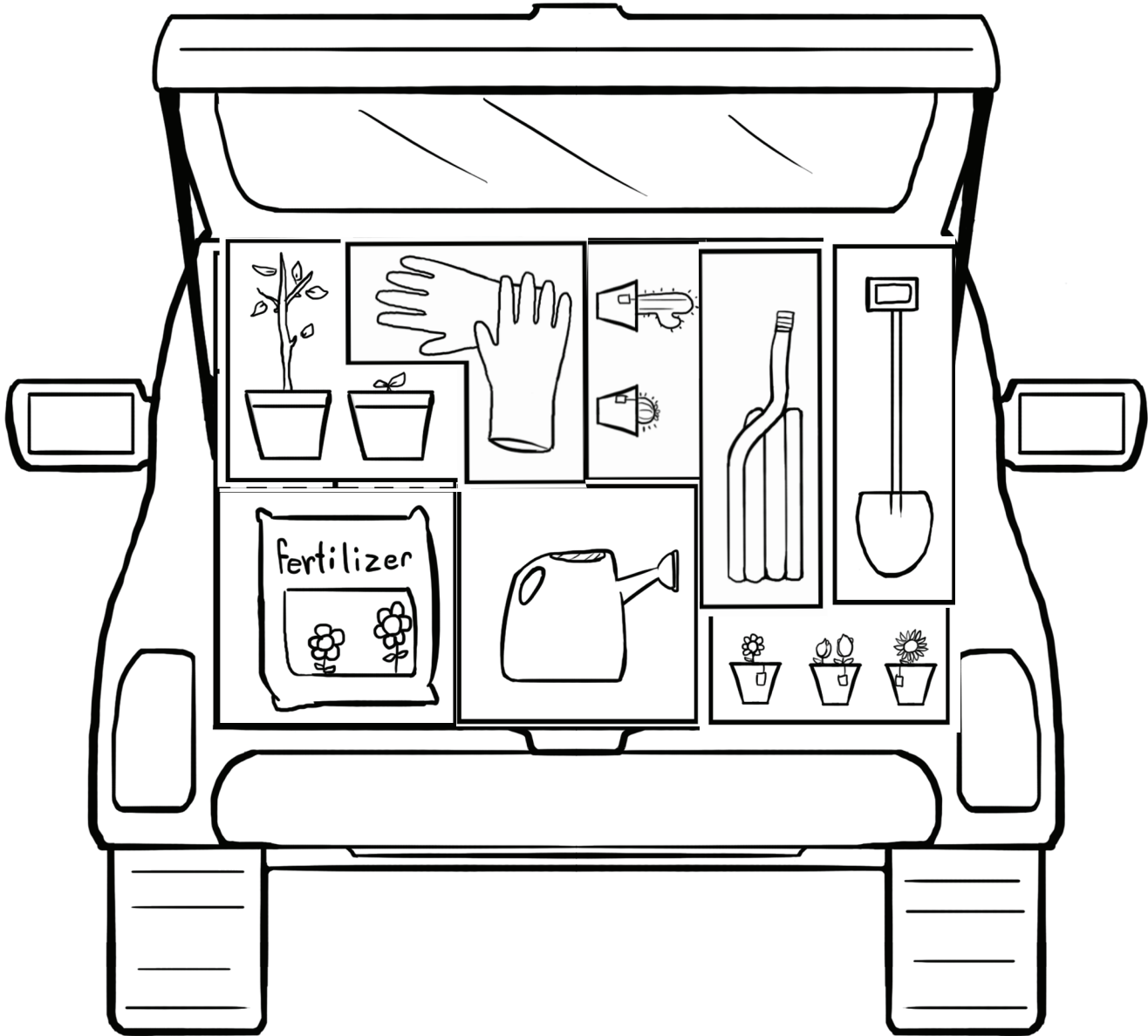

Cut out the shapes below and place them inside the dotted line area in the cart trunk above. Try turning some shapes around to see if they'll fit!

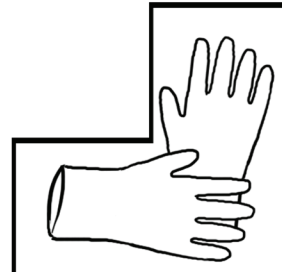
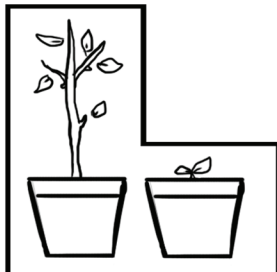
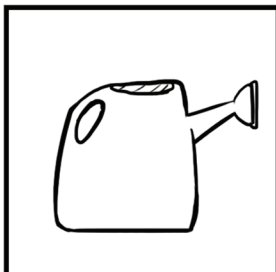
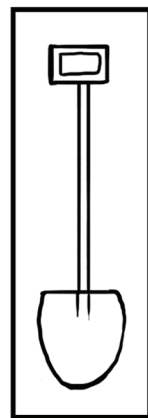
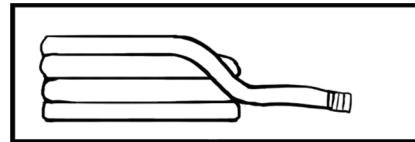
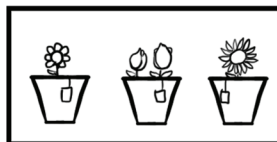
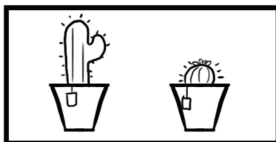

Answer Key

Will it fit?



Cut out the shapes below and place them inside the dotted line area in the toy chest above. Try turning some shapes around to see if they'll fit!

